

EcoMo Auto Operation High Speed Hand Dryer



EcoMo



EcoMo Auto Operation High Speed Hand Dryer

High Speed Hand Dryer Solutions

The EcoMo Auto Operation High Speed Hand Dryer Much more than you expect!

EcoMo is an ergonomic, auto operation high speed hand dryer. Offering a comfortable, natural drying position, users can effectively dry their hands without water splash-back. EcoMo is an ideal solution for high traffic washrooms, with its absorbent, ceramic pad that prevents water overflow. Unlike other vertical hands-in dryers, the drying area is the perfect size for hands without losing drying efficiency. EcoMo's anti-bacterial protection cover and super HEPA filter, which eliminates over 99% of any present bacteria gives users extra protection against harmful bacteria.

EcoMo Auto Operation High Speed Hand Dryer

High Speed Hand Dryer Solutions



ML_ECOMOROUND_SIL

ML_ECOMOROUND_BLK

ML_ECOMOROUND_WHT

SPECIFICATIONS

Cover/ Specify	3.0mm thick moulded Antibacterial ABS plastic White: ML_ECOMOROUND_WHT Silver: ML_ECOMOROUND_SIL Black: ML_ECOMOROUND_BLK
Motor	350-700 W, 12,000-18,000 R.P.M., Adjustable Brush Motor
Motor Thermal Protection	Auto resetting thermostat turns unit off 240V/277V at 95°C
Power Use	220-240 Vac, 50/60Hz, 6.1-6.7 A, 1.34-1.6kW
Standby Power	0.3-0.4W
LED Colour	Standby: Red, Active: Blue
Sound Level	Min 72.2 dB to 75.4 dB MAX at 1m
Drying time	10-15 seconds
Drip Proof	IP 21 or IP24 (Optional)
Heater Element	ON/OFF switch available. Power 450-900W depending on air speed
Heater Thermal Protection	Auto resetting thermostat turns unit off at 85°C Thermal cut-off at 142°C
Warm Air Speed	75-90 m/s (adjustable)
Air Output	55°C - Ambient Temp. 25°C
Timer Protection	60 seconds auto shut off
Circuit/ Sensor Range	Circuit Operation- Infrared Automatic, self adjusting Sensor Range Standard 170mm ± 20mm Adjustable
Case Security	SS theft resistant hex drive screws (hex key supplied)
Net Weight	9.4kg
Dimensions	322mmW x 624.5mmH x 185mmD
Filter	Super Filter Assembly consisting of Antibacterial Filter+Carbon Filter + HEPA Filter
Warranty	5 Year Warranty (3 Years Parts and Labour + 2 Years Parts only)
Note:	* Unit can be hard wired by electrician or used with cord and plug provided * This unit is disabled compliant when installed in accordance with AS1428.1. guidelines.

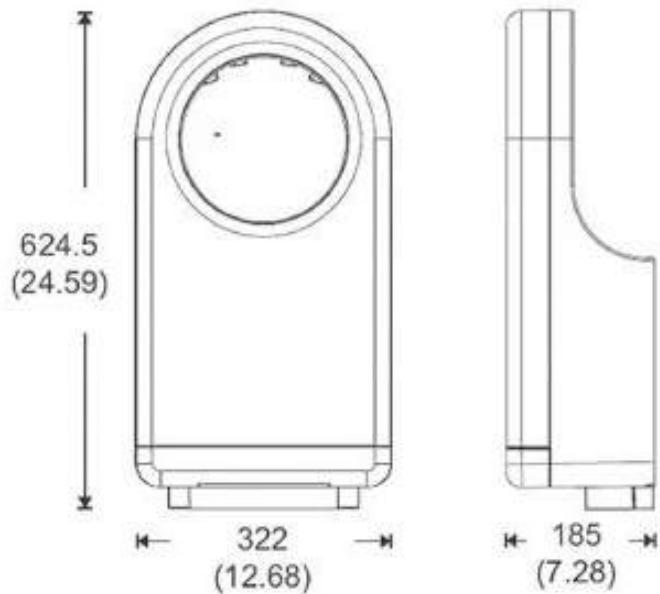

Safety Approvals



Green Certificates



EcoMo Auto Operation High Speed Hand Dryer

High Speed Hand Dryer Solutions

Recommended Mounting Heights

Above Finished Floor (AFF)

This unit is accessible compliant when installed in accordance with AS1428.1 guidelines.



A
From Top of Hand Drying Chamber

B
From Datum Point

C
From Bottom of Dryer

	A	B	C
Men	1168mm	728mm	640mm
Women	1168mm	728mm	640mm
Children 4-7 years	730mm	290mm	202mm
Children 8-10 years	830mm	390mm	302mm
Children 11-13 years	965mm	525mm	437mm
AS1428.1 Compliant (Accessible)	1168mm	728mm	640mm

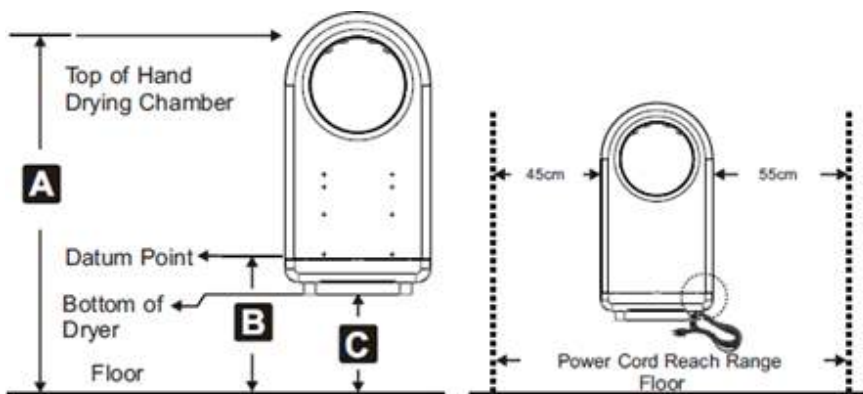

Socket Location

The dryer is supplied with a power cord. The power cord entry position is in the rear, right side bottom of dryer. The length of the power cord is 1M. The power cord can reach to the right side within the distance of 55cm and reach to the left side within the distance of 45cm. Alternatively the unit may be hard wired to a terminal block through a rear panel Knock Out.

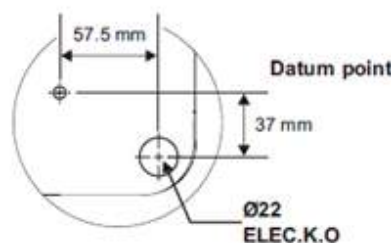

Detail A Unit Rear

EcoMo Auto Operation High Speed Hand Dryer

High Speed Hand Dryer Solutions

General Safety Information

▲ WARNING This product is intended for installation by a qualified service person. Use 1.5 mm² solid conductor for wiring. (for 220-240V)

▲ DANGER Failure to properly ground unit could result in severe electrical shock and/or death.

▲ WARNING Disconnect power at the circuit breaker or fused spur before installing or servicing. Not for household usage - may cause burns.

▲ WARNING All units must be supplied with a 3-wire service. The ground wire must be connected to the dryer's backplate.

Installation Steps

1. Tape the installation template to the appropriate location on the mounting surface. Drill eight (8) holes at marked locations.(fig. 1).
2. Remove template and Insert eight (8) plastic anchors (supplied) into drilled holes (fig. 2).
3. Insert eight (8) screws (supplied) to fix backplate into top plastic anchors (fig. 3).
4. Hang the dryer on the base plate (fig. 4).
5. Use Allen key (supplied) to unlock and withdraw filter access drawer. Tighten locking screw through the hole at the bottom of the dryer. Insert the filter access drawer back into the dryer and lock the security screw. (fig. 5).
3. a. Connect hard wired power provided at K.O. location to terminal block behind cover panel (RH-bottom) behind filter access drawer. Turn on circuit breaker to initiate 'stand by- ready to operate' status.

Connections:

- A. Connect the live wire (Brown) to the terminal block marked "L".
 - B. Connect the neutral wire (Blue) to the terminal block marked "N".
 - C. Connect the ground wire to the terminal block marked "⊕". Bare grounding (earth) wires should be sleeved with green and yellow tubing.
- Colors of live and neutral wires depend on voltage of supply service and requirements of Building and Electrical Code having jurisdiction.
- b. Energize power supply to initiate 'stand by- ready to operate' status.
7. Replace the filter access drawer, being careful to not over-tighten the security screw.
 3. See separate sections for owner options on heater operation and air speed adjustment.

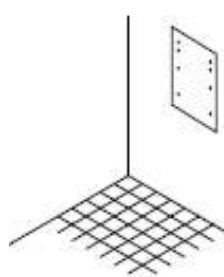

(fig. 1)

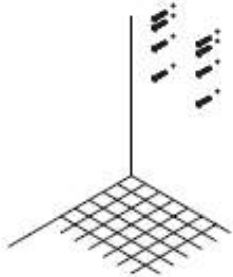

(fig. 2)

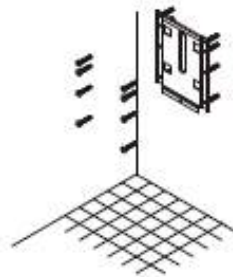

(fig. 3)

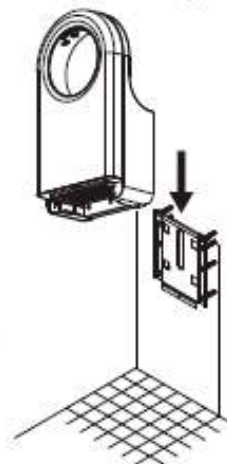

(fig. 4)



(fig. 5)

EcoMo Auto Operation High Speed Hand Dryer

High Speed Hand Dryer Solutions

Cleaning & Maintenance

Periodic cleaning of the unit is recommended to ensure optimum performance.

- Wipe the cover with a damp cloth and mild cleaning solution.
- Do not Soak, Do not hose down.
- Never use abrasives to clean the cover. Caustic chemicals may damage unit finish.
- No internal parts need any regular cleaning.

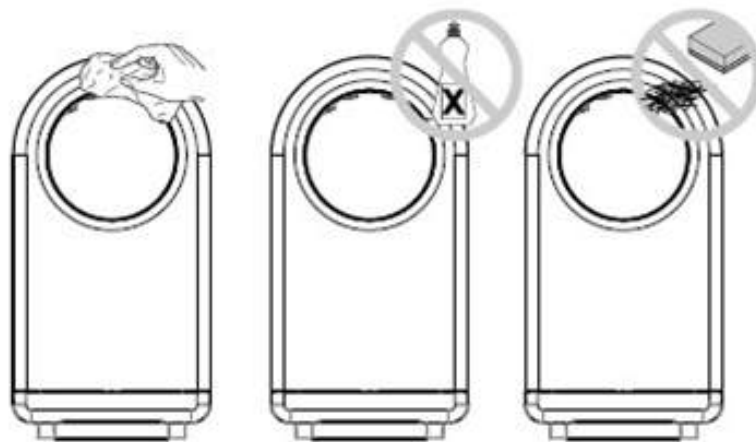

Circuit Diagram

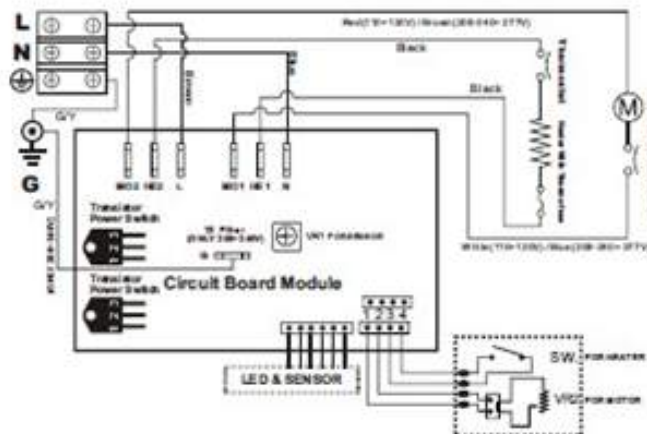

Operation

- 1 Put your hands through the opening.
- 2 Dry hands like you wash them.
- 3 Remove hands and dryer will stop automatically.



EcoMo Auto Operation High Speed Hand Dryer

High Speed Hand Dryer Solutions

Air Speed Adjustment

It is possible to adjust the speed of the dryer to change the sound level during operation. However, when lowering the motor speed, the drying time will increase.

The usefulness of this function will be dependent on the needs of the owner. The factory setting for dryer's motor speed will be set at its highest speed.

See below for how to adjust the dryer speed:

1. Use Allen key (supplied) to unlock and withdraw the filter access drawer.(fig. 1).
2. Use a small flat blade screwdriver to gently turn adjustment potentiometer(fig. 2) shaft clockwise [CW] to increase power to maximum (shaft will hard stop; DO NOT OVERTURN!).
3. Turn tool gently CCW to reduce power as required (shaft will hard stop; DO NOT OVERTURN!).
Note that at minimum power the unit may not start if there is low line Voltage.
4. Insert the filter access drawer back into the dryer and lock the security screw.

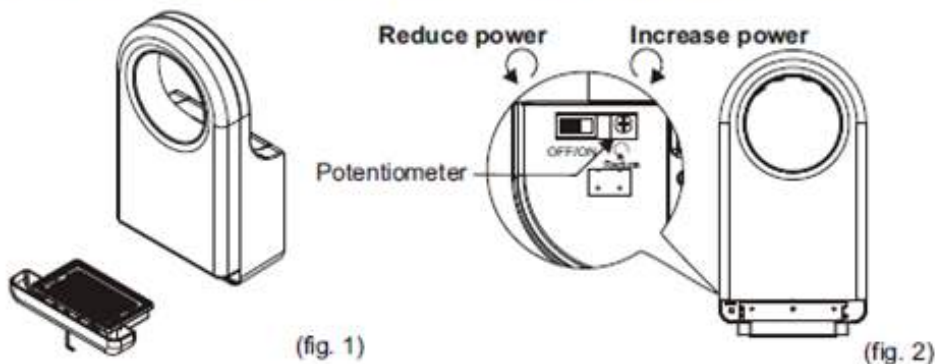

Heater Element Switch ON/ OFF

The dryer has been designed with a heater switch that can turn the heater ON & OFF. The heater switch doesn't affect the drying time. In cold climate location, it may be more comfortable if the heat it is on when drying hands. However, it will save a third of the energy used if the switch is off. This function can be adjusted depending on the needs of the owner.

The factory setting for the heater will be on.
See below for how to turn the heater ON/OFF.

1. Use Allen key (supplied) to unlock and withdraw filter access drawer.(fig. 1).
2. Turn the Switch to the right to turn the heater ON. Switch it to the left to turn the heater OFF. (fig. 2)
3. Insert the filter access drawer back into dryer and lock the security screw.

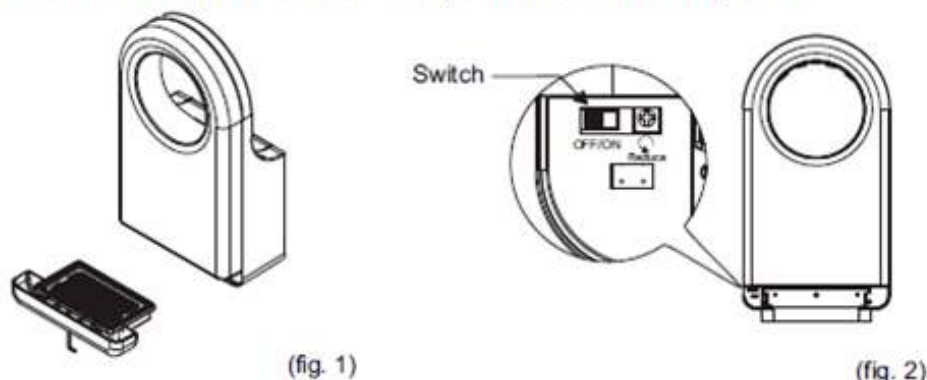

EcoMo Auto Operation High Speed Hand Dryer

High Speed Hand Dryer Solutions

How to change the SUPER filter

1. Use Allen key (supplied) to unlock and withdraw filter access drawer.(fig. 1)
2. Change the SUPER filter(fig. 2).
3. Insert the filter access drawer back into the dryer and lock the security screw.

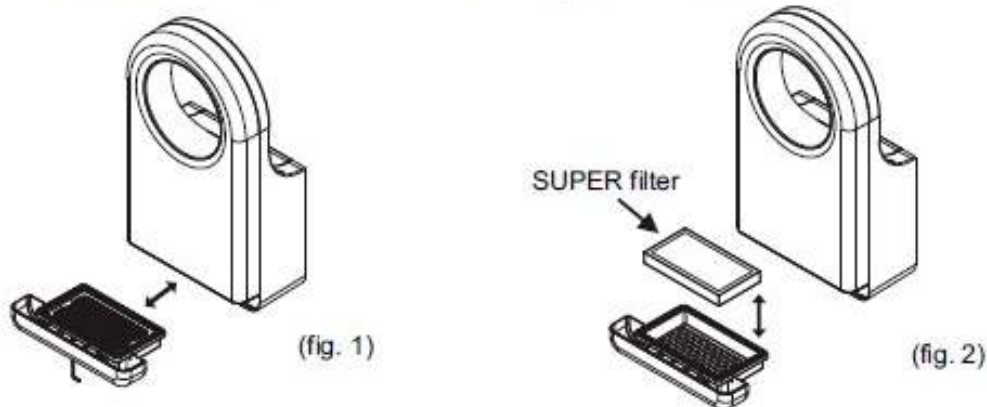

Recommended Period for Changing the SUPER filter

SUPER Filter-

In general use (normal indoor toilets), it's recommended to change the SUPER filter every six (6) months. In dusty and high usage places (factories, outdoor & public toilets), it's recommended to change it every three (3) months.

SUPER filter Assembly Information

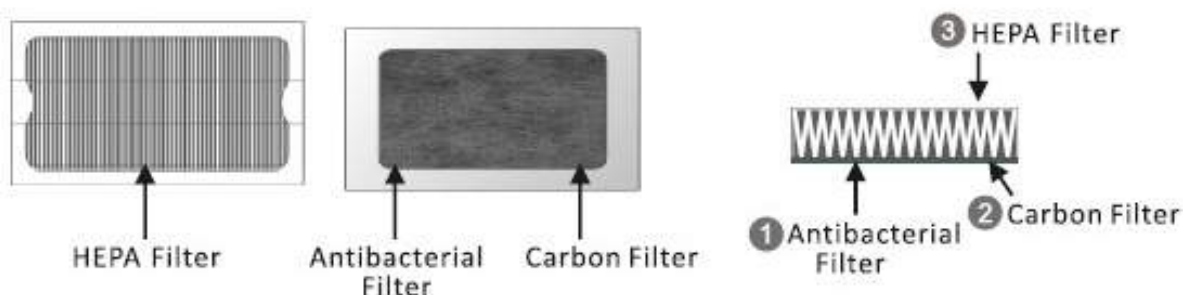

EcoMo Auto Operation High Speed Hand Dryer

High Speed Hand Dryer Solutions

Instructions for use, maintenance and changing the absorbent ceramic pad

The absorbent ceramic pad can absorb 70g of water, and has the capacity to take a full load approximately 280 times per day. The ceramic pad also can evaporate water. During normal use, water will be evaporated continuously and maintains its function of absorbing water. The ceramic's ability to absorb water decreases after long periods of use because it gets covered by dirt and dust. In this case, please use an abrasive sponge to wipe the surface, and the performance and function will then return to normal. Improper use or maintenance could result in breakage; see below for replacement instructions.

1. Remove drain tray if fitted then use the Allen key Supplied to loosen the security screw and remove the filter access drawer. (fig. 1)
2. Use the Allen key to loosen the security screw from the base plate and remove the dryer from the wall. (fig. 2)
3. Use a screwdriver to remove the two screws holding the ceramic pad and replace it with a new one. (fig. 3)
4. Re-Install the dryer on the base plate and secure the security screw back into the base plate.
5. Re-install the filter access drawer back and tighten the security screw.
6. It is recommended to replace the ceramic pad every year.

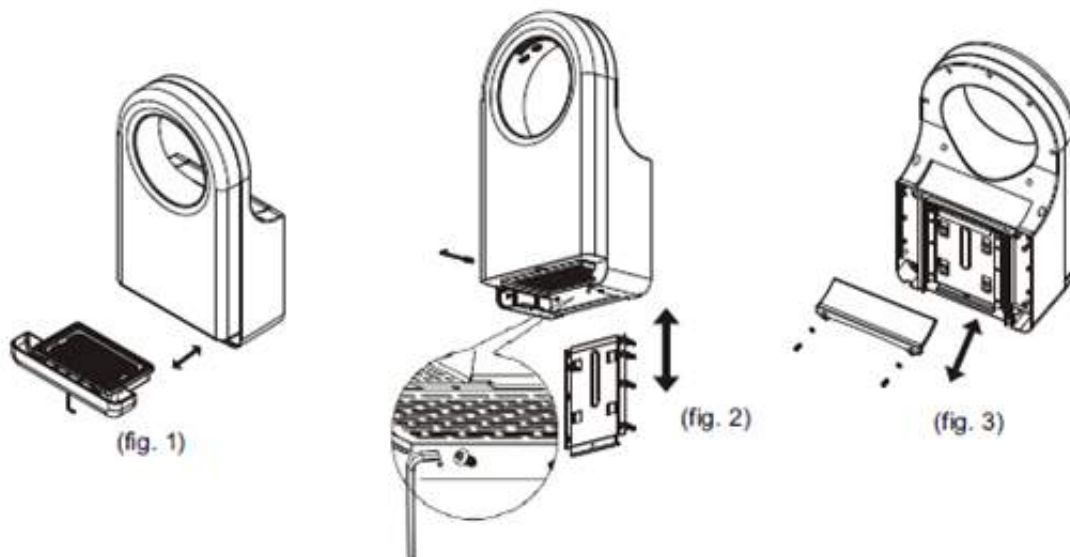

Instructions for use of the drain tank

Generally, the water remaining following usage will evaporate in the absorbent ceramic pad. During high usage periods, leftover water will flow into the drain tray automatically. The capacity of the drain tray is 240 ml. It's recommended to clean the drain tray every 3 months; water will come through the "overflow hole" if the drain tray is full. A drainpipe (not included) can be added if necessary. The specifications of the drainpipe is I.D. 6mm, O.D. 10mm (fig. 1)



EcoMo Auto Operation High Speed Hand Dryer

High Speed Hand Dryer Solutions

Parts Replacement & Disassembly Steps

1. Make sure power is OFF before starting step fig 1.
2. Either unplug power cord or disconnect in-wall power connections behind terminal cover prior to starting step fig 2.

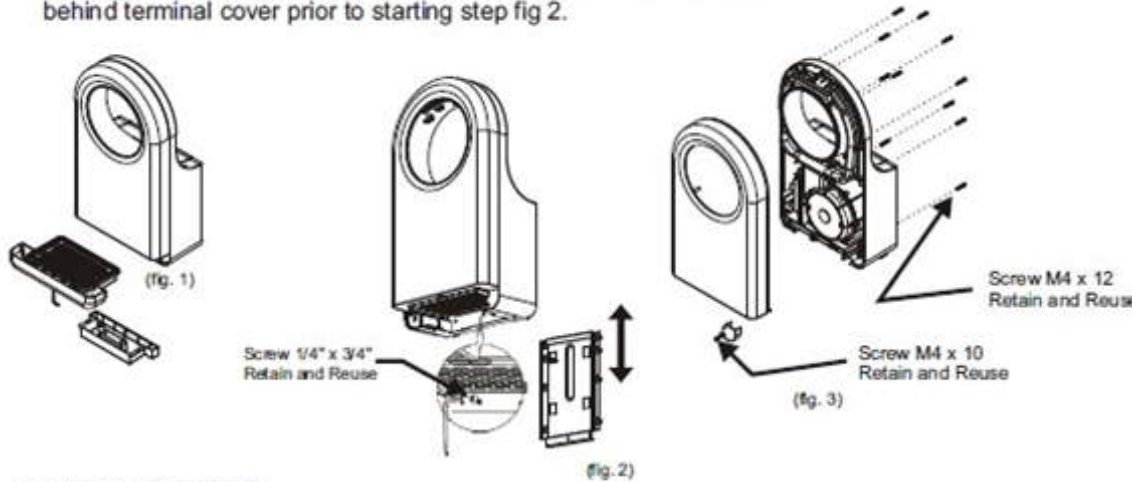

Motor Replacement

Start with steps fig's 1-3

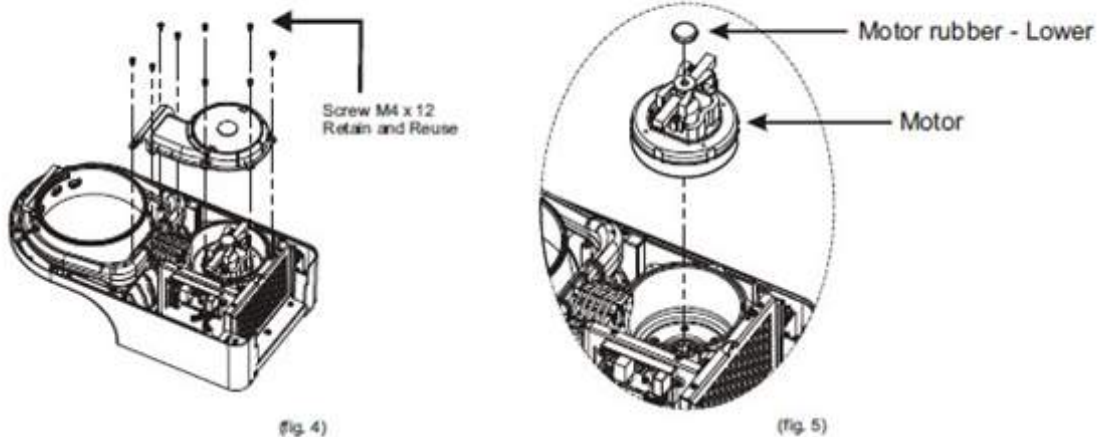

Brush Replacement

Start with steps fig's 1-3. Remove blower housing upper see step fig. 4 under motor replacement.

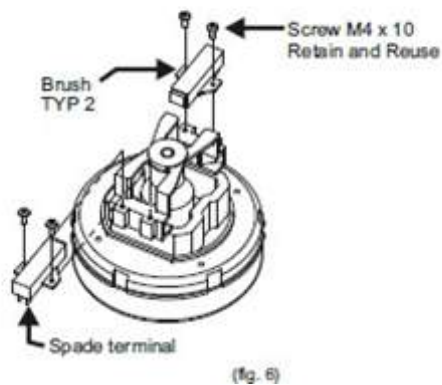

Heater Replacement

Start with steps fig's 1-3. Remove blower housing upper see step fig. 4 under motor replacement.

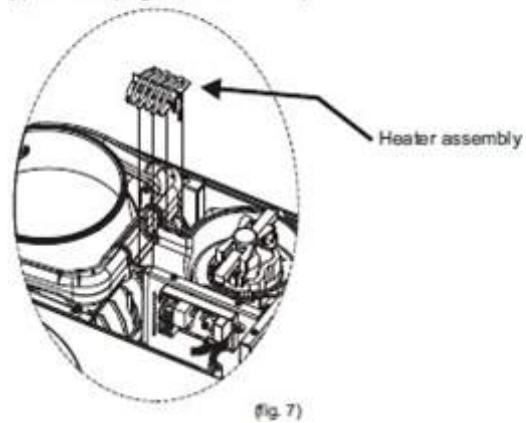

EcoMo Auto Operation High Speed Hand Dryer

High Speed Hand Dryer Solutions

Parts Replacement & Disassembly Steps

CBM Replacement

Start with steps fig's 1-3

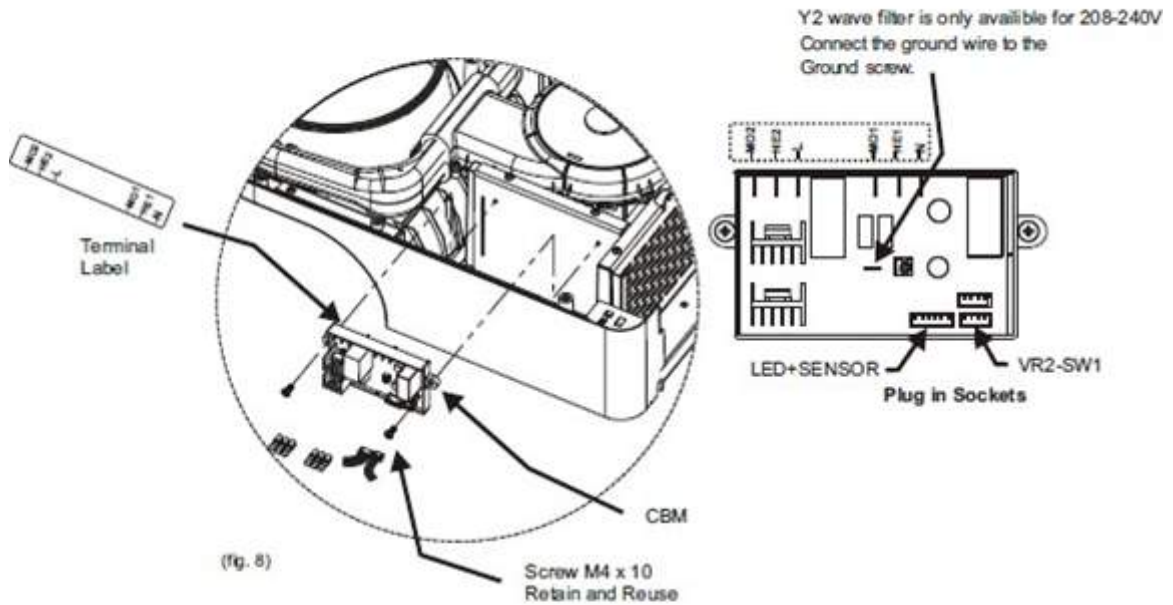

Heater ON/OFF - Speed Control - CBM Replacement

Start with steps fig's 1-3

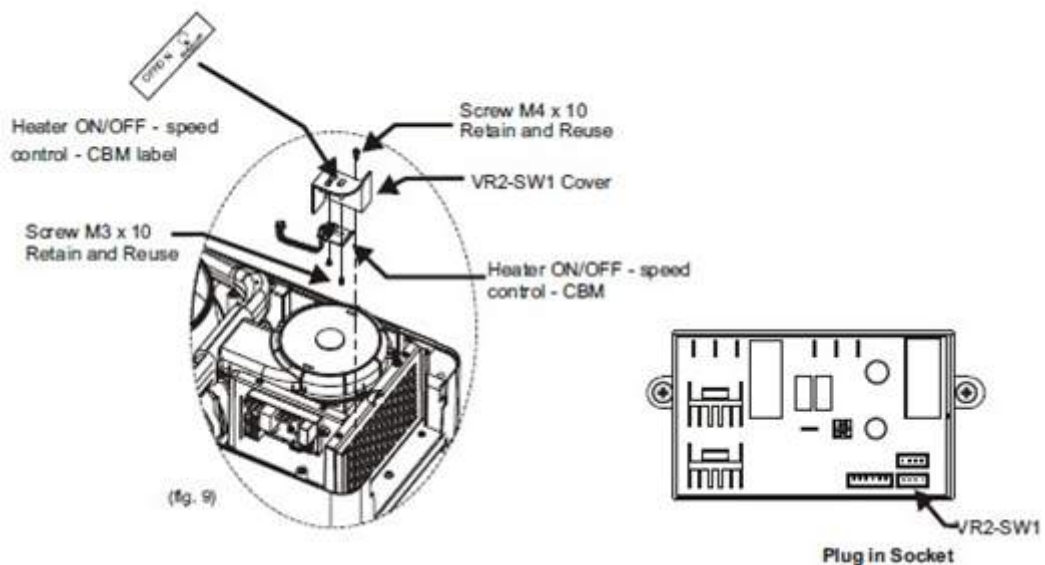

EcoMo Auto Operation High Speed Hand Dryer

High Speed Hand Dryer Solutions

Parts Replacement & Disassembly Steps

Sensor Module Replacement

Start with steps fig's 1-3

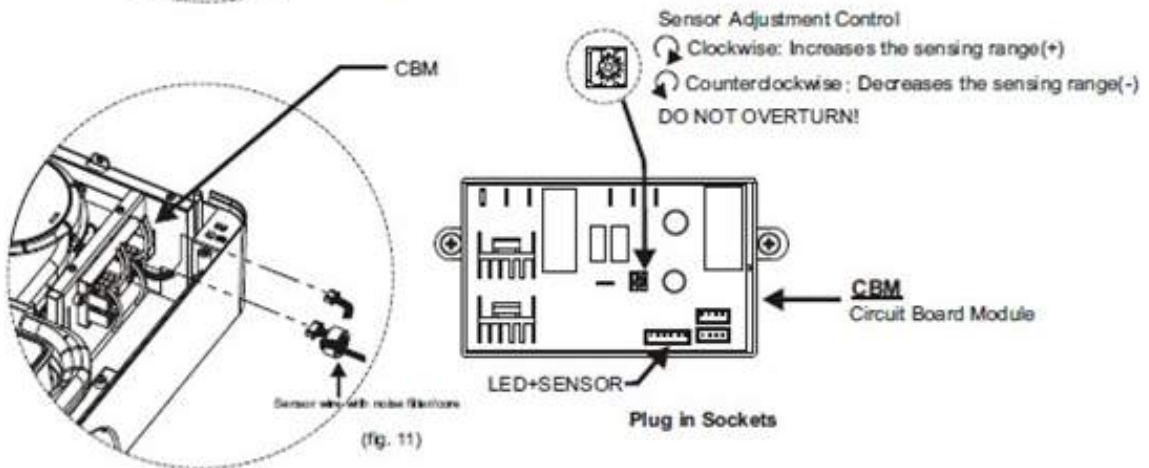
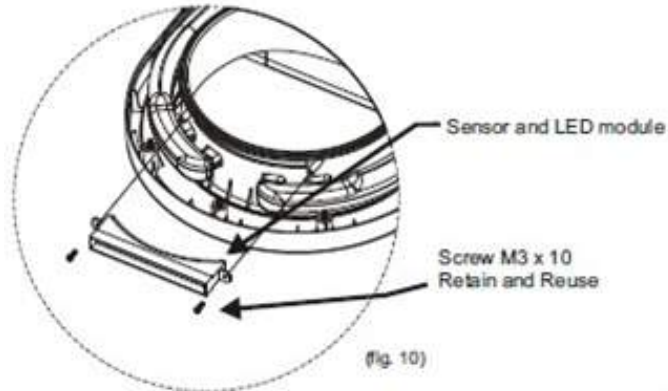

Nozzle Manifold Replacement

Start with steps fig's 1-3. Remove blower housing' upper see step fig. 4 under motor replacement.

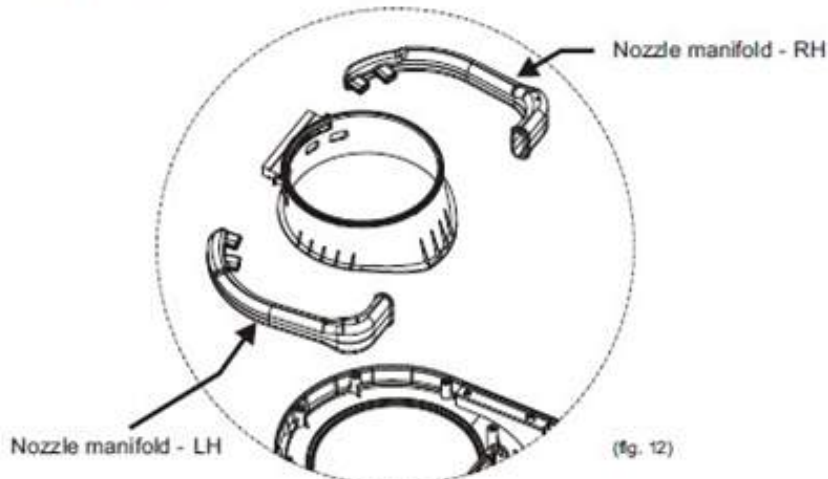

EcoMo Auto Operation High Speed Hand Dryer

High Speed Hand Dryer Solutions

Parts Replacement & Disassembly Steps

Chamber Replacement

Start with steps fig's 1-3. Remove blower housing upper see step fig. 4 under motor replacement.

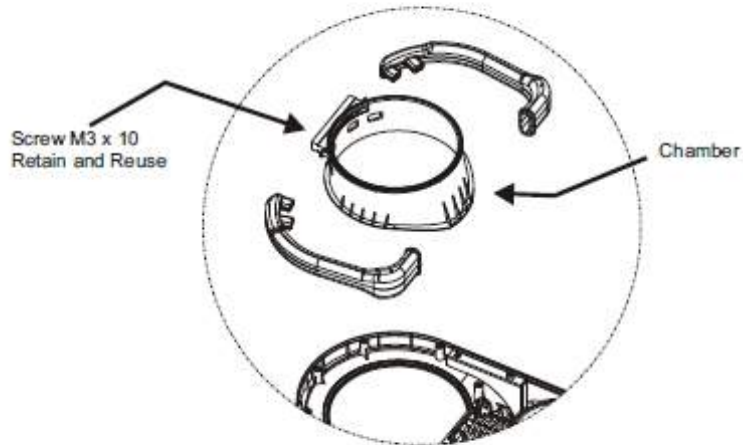

(fig. 13)

Conversion from power cord (as supplied) to in-wall power supply (by others).

Start with steps fig's 1-3. Make sure power is OFF before starting.

Remove power cord from terminal block and strain relief using C-socket wrench provided. Connect power supply (by others) in appropriate voltage for model selected at location per diagram in detail A (pg.2 this manual) and step 5.b. (pg. 3 this manual). Feed power cord into cord-grip strain relief and follow step 6.a. Connections A-C (pg. 3 this manual).

Insertion of 1.0mm² -1.5mm² stranded wires into terminal block receptacles will be easier and provide better results if crimp-on wire tips are installed on wire ends prior to feeding cable through cord-grip. If solid wire power cable is used, crimp on tips are not required.

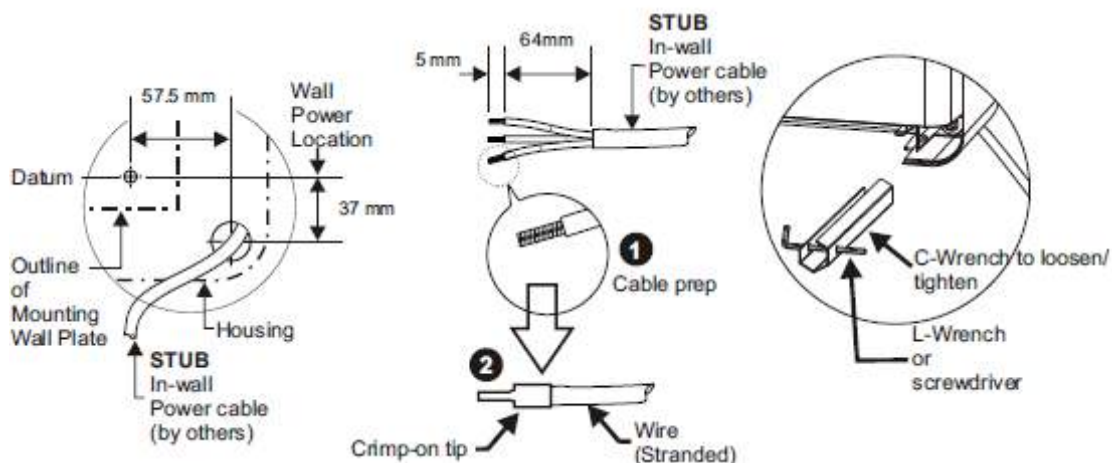

EcoMo Auto Operation High Speed Hand Dryer

High Speed Hand Dryer Solutions

Repair Parts List

Key	Description
1	Drawer assembly
2	SUPER Filter
3	Filter rubber
4	Switch cover
5	Cover
6	Motor housing (Upper)
7	Motor housing rubber
8	Motor rubber (Small)
9	Motor
10	Motor brush
11	Motor rubber (Large)
12	Heater assembly
13	Motor housing (Lower)
14	Air outer (right)
15	Air outer (left)
16	Chamber
17	Sensor & LED PCB module
18	Bracket (right)
19	Bracket (left)
20	Security hex screw
21	Main PCB module
22	Air inlet gate
23	Main PCB module bracket
24	Main bracket
25	Water reservoir
26	Switch cover
27	Terminal block
28	VR & Switch PCB
29	Cable gland
30	Back cover
31	Wall bracket
32	Backplate
33	Ceramic absorber
34	L-Wrench
35	C-Wrench
36	Crimp-on wire tips for terminal block

EcoMo Auto Operation High Speed Hand Dryer

High Speed Hand Dryer Solutions

Diagram

Tools Req'd (Provided in kit)

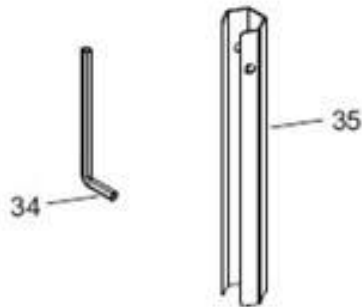

Optional Terminals
(Provided in kit)

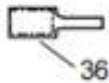

Use 1.0-1.5 mm²(AWG 16-14)(MAX)

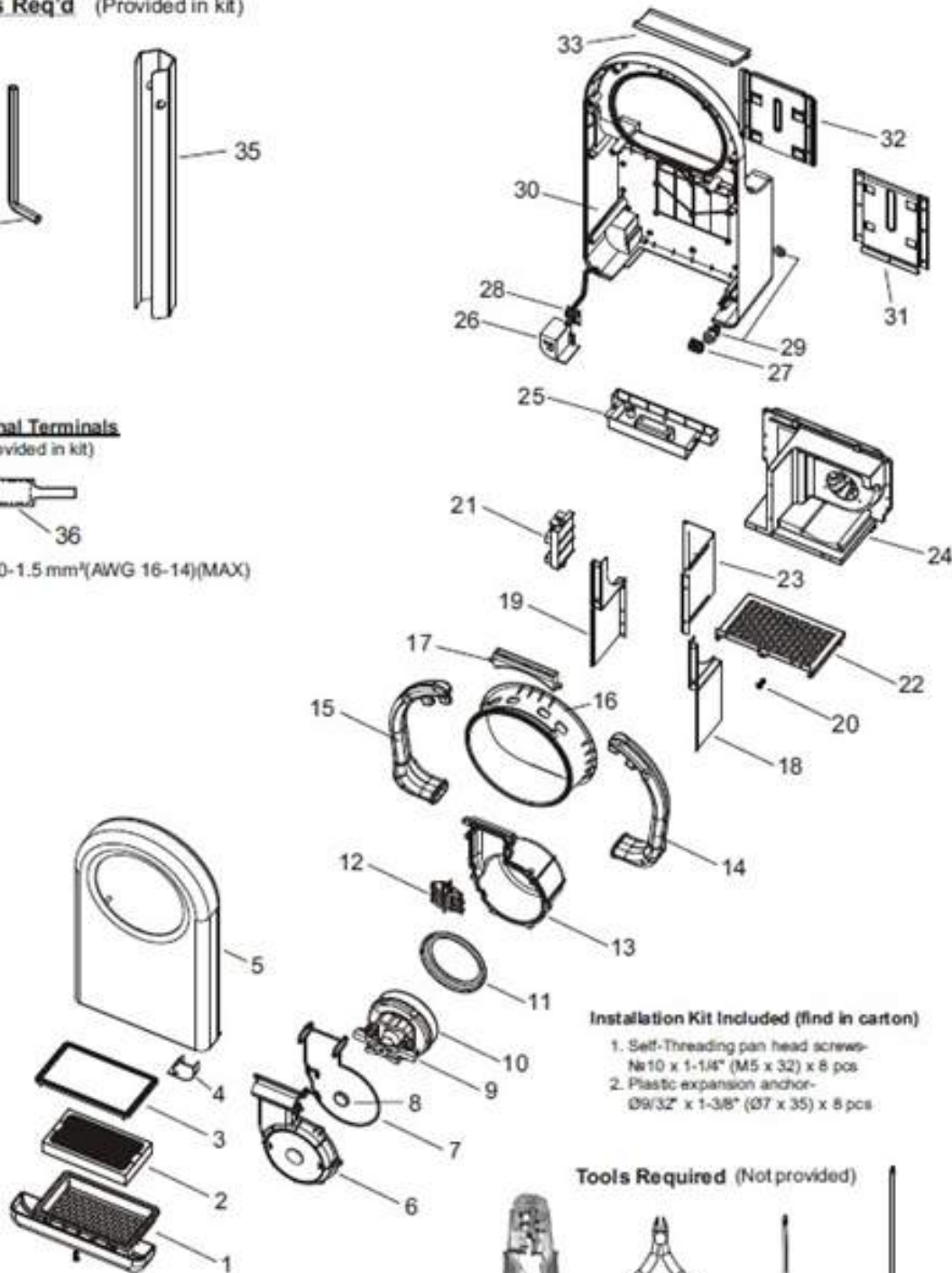

Installation Kit Included (find in carton)

1. Self-Threading pan head screws-
No 10 x 1-1/4" (M5 x 32) x 8 pos
2. Plastic expansion anchor-
Ø9/32" x 1-3/8" (Ø7 x 35) x 8 pcs

Tools Required (Not provided)

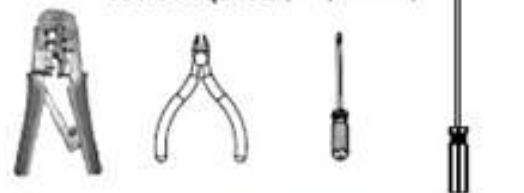

Crimp tool Wire Cutter Flat blade Philips #1/ #2

EcoMo Auto Operation High Speed Hand Dryer

High Speed Hand Dryer Solutions

Warranty

Warranty

The product warranty is 5 years (3 years Parts and Labour plus 2 years parts only) from the date of purchase.

For more information, please email service@metlam.com.au to get a copy of Metlam Australia's Warranty Statement

For service related enquiries email: service@metlam.com.au

The technical recommendations contained in this document are necessarily of a general nature and should not be relied on for specific applications without first securing competent advice. Whilst Metlam Australia Pty Ltd has taken all reasonable steps to ensure the information contained herein is accurate and current, it does not warrant the accuracy or completeness of the information and does not accept liability for errors or omissions. Any Commercial product should only be installed by a competent tradesperson and serviced/maintained by knowledgeable janitorial staff or competent people. Metlam Australia accepts no responsibility for any damage to product, walls or fixtures due to incorrect installation or maintenance of any of their products.

